



**PACKAGE CONTENTS:** 1x Bin, 1x Lid, 2 Waste Bag Hooks

**DIMENSIONS:** 20in W x 20in D x 38.75in H (45 Gallon Capacity)

**IMPORTANT NOTE:**

The Berkshire is a multi-purpose storage bin that can be used for storing a wide variety of house hold items and supplies like sand or salt for de-icing the driveway during winter months. Please store sand or salt in the original packaging or an inserted receptacle. Pouring it directly into the bin will apply too much force on the walls which may cause bowing.

In the event of missing or defective parts, please email [customerservice@gomayne.com](mailto:customerservice@gomayne.com) or call our customer service department toll free at 866-363-8834. (available Monday through Friday, 8am-5pm EST)

**General Information:**

- Read instructions carefully before beginning assembly.
- To clean the product, for best results use a soap solution and high-pressure water.
- Hooks are included to hold standard waste bags
- Will hold an insert receptacle up to 14.5in L x 14.5in W x 30in H

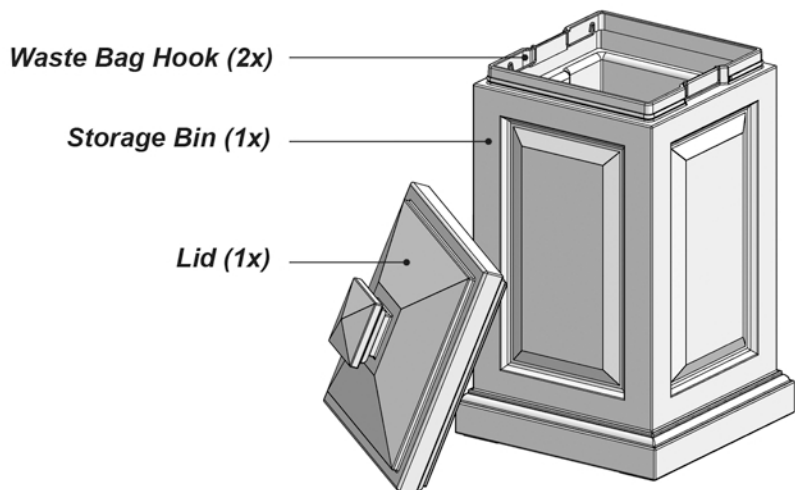
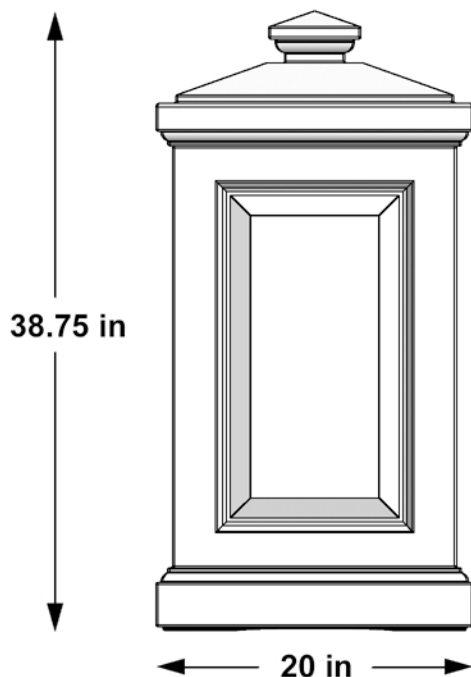

1

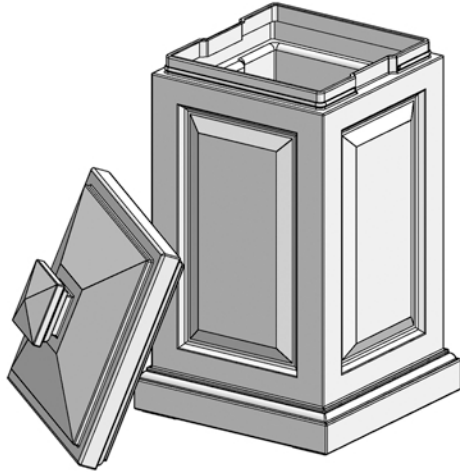

The Berkshire Storage Bin includes a bin, lid, and 2 waste bag hooks.

2

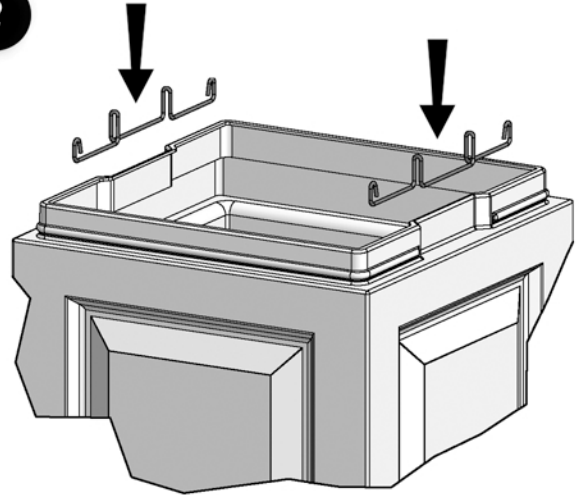

Align the hooks along the recessed areas and slip the brackets over the lip of the bin.

3

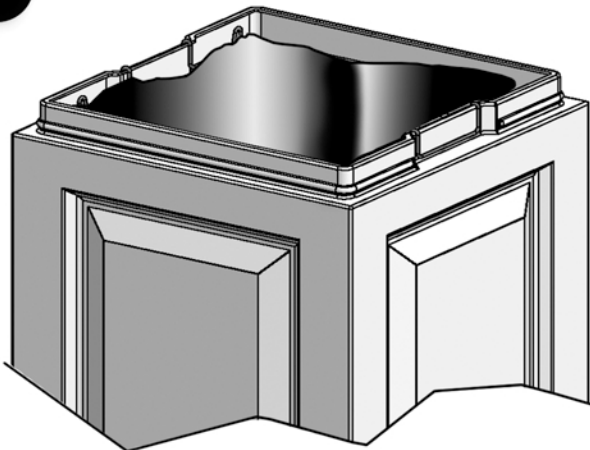

Hooks are designed to hold standard waste bags.

4

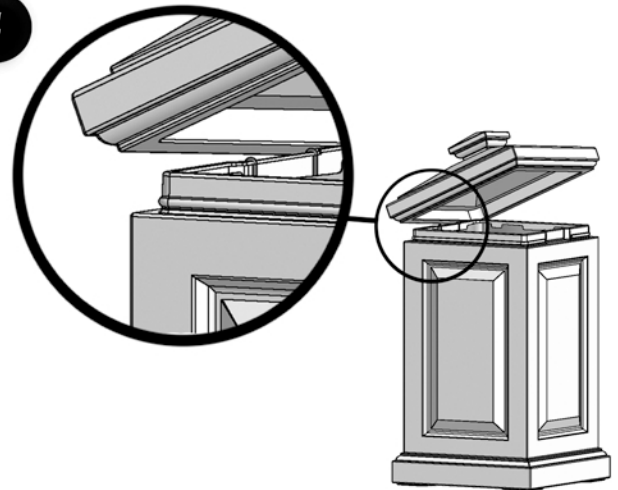

Snap fit lid design for secure fit.

In the event of missing or defective parts, please email [customerservice@gomayne.com](mailto:customerservice@gomayne.com) or call our customer service department toll free at 866-363-8834. (available Monday through Friday, 8am-5pm EST)